

Dimension Table

Unit:mm

Size	A(B)	ød	øD	øD1	øD2	øC	n-øh	e	Recommend Fasten Torqu N·m
□ 13(3/8)	17	73	24	36	55	4-12	2.0	15	
□ 15(1/2)	20	78	28	40	60	4-12	2.0	15	
□ 20(3/4)	25	83	33	45	65	4-12	2.0	15	
□ 25(1)	30	93	38	52	75	4-12	2.0	30	
□ 32(1-1/4)	38	113	46	61	90	4-15	2.5	30	
□ 40(1-1/2)	46	118	54	68	95	4-15	2.5	30	
□ 50(2)	58	128	66	80	105	4-15	2.5	30	
□ 65(2-1/2)	73	153	82	100	130	4-15	2.5	45	
□ 80(3)	84	178	94	113	145	4-19	4.0	45	
□ 100(4)	106	198	116	135	165	8-19	4.0	45	
□ 125(5)	131	233	142	164	200	8-19	4.0	55	
□ 150(6)	155	263	168	190	230	8-19	4.0	55	
□ 200(8)	204	318	220	243	280	8-23	4.0	55	
□ 250(10)	254	383	270	300	345	12-23	4.0	65	

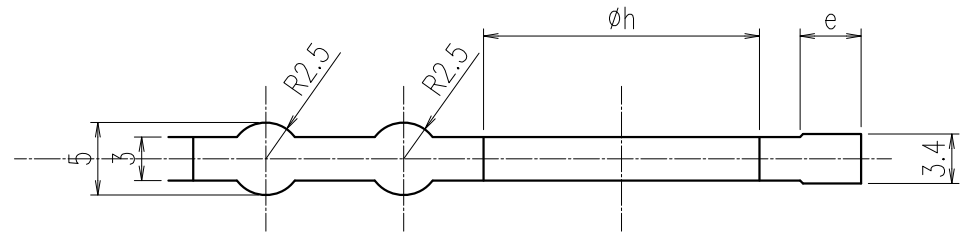

Client name		Date
Oil Free	<input type="checkbox"/> YES	Approved by:
ESILON EPDM GASKET JIS5K 13-250A Drawing No. PK132F_EP_EE		
SEKISUI SEKISUI CHEMICAL CO.,LTD.		

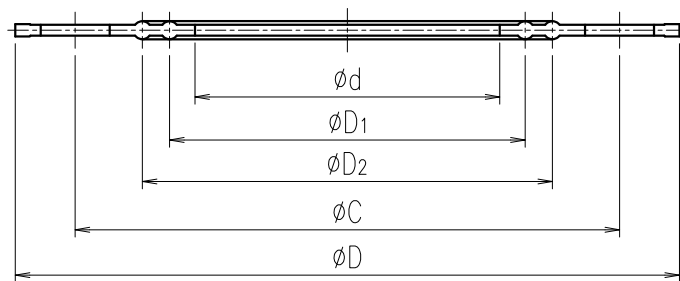
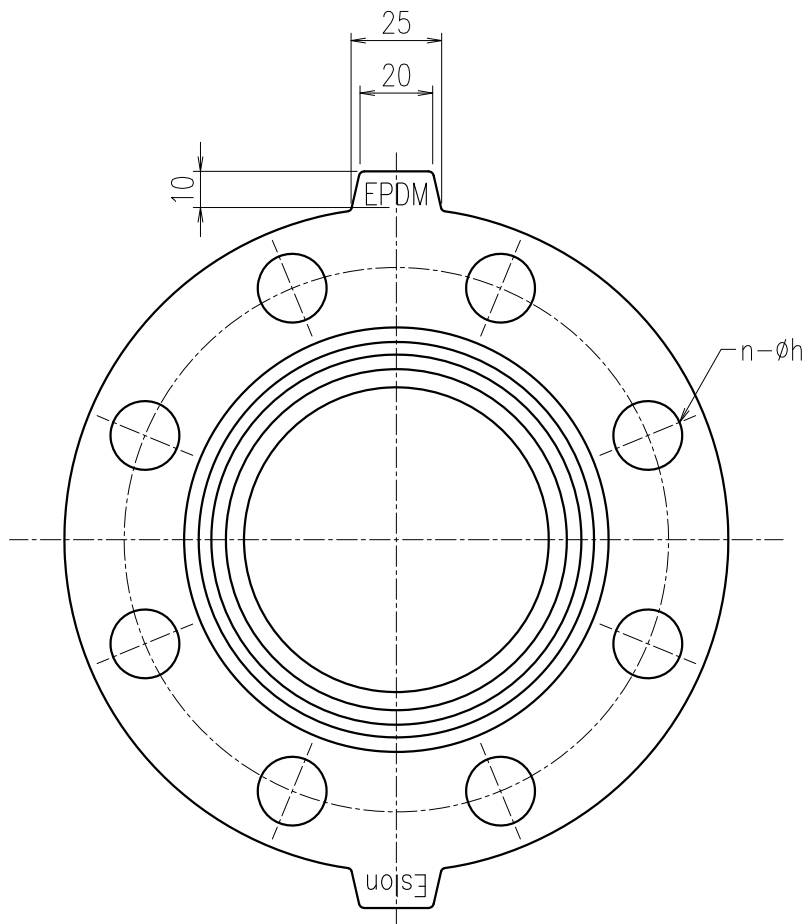

Dimension Table

Unit:mm

Size	A(B)	ϕd	ϕD	ϕD_1	ϕD_2	ϕC	$n-\phi h$	e	Recommend Fasten Torqu N·m
□ 13(3/8)	17	88	25	38	65	4-15	2.0	15	
□ 15(1/2)	20	93	28	42	70	4-15	2.0	15	
□ 20(3/4)	25	98	33	47	75	4-15	2.0	15	
□ 25(1)	30	123	38	53	90	4-19	3.0	30	
□ 32(1-1/4)	38	133	48	63	100	4-19	3.0	30	
□ 40(1-1/2)	46	138	54	69	105	4-19	4.0	30	
□ 50(2)	58	153	68	83	120	4-19	4.0	30	
□ 65(2-1/2)	73	173	86	101	140	4-19	4.0	45	
□ 80(3)	84	183	98	113	150	8-19	4.0	45	
□ 100(4)	106	208	120	138	175	8-19	4.0	45	
□ 125(5)	131	248	145	168	210	8-23	5.0	55	
□ 150(6)	155	278	170	196	240	8-23	5.0	55	
□ 200(8)	204	328	218	248	290	12-23	5.0	55	
□ 250(10)	254	398	270	306	355	12-25	5.0	65	
□ 300(12)	304	443	324	356	400	16-25	5.0	65	
□ 350(14)	352	488	368	400	445	16-25	5.0	65	

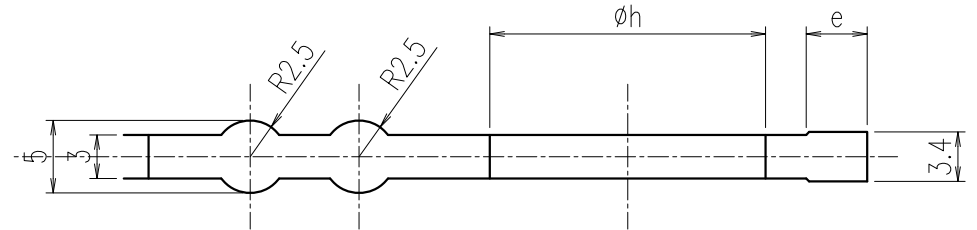

Client name		Date
Oil Free	<input type="checkbox"/> YES	Approved by:
ESLON EPDM GASKET JIS10K 13-350A Drawing No. PK133F_EP_FE		
SEKISUI SEKISUI CHEMICAL CO.,LTD.		

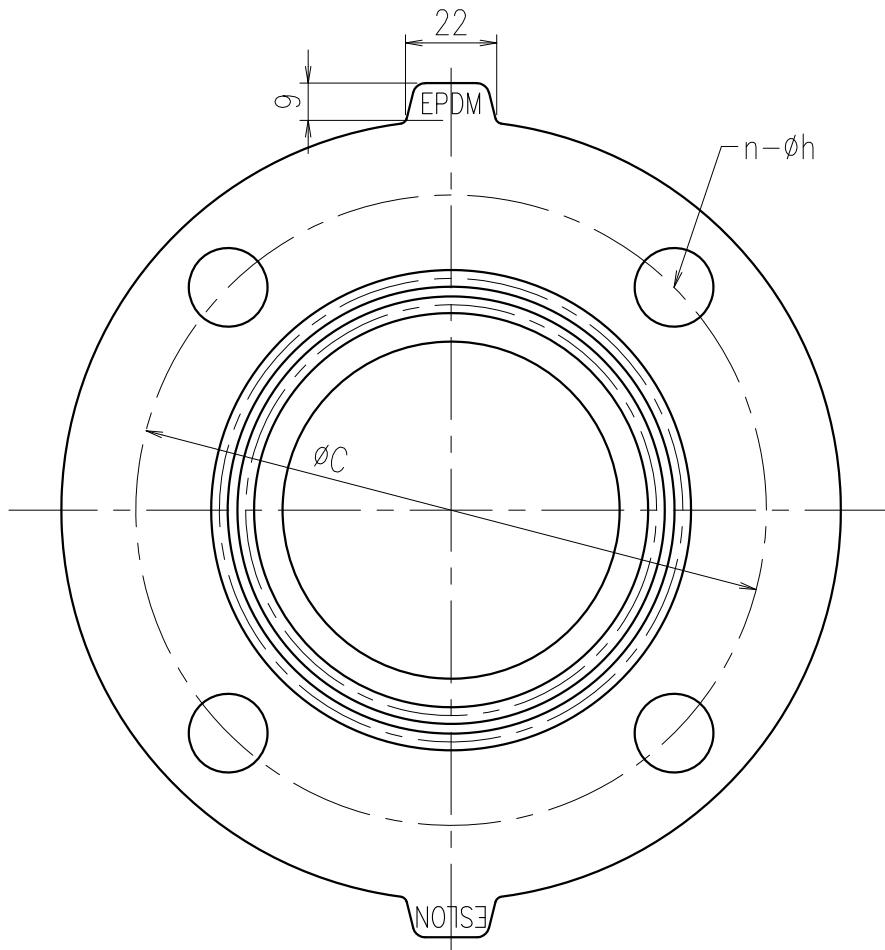

Dimension Table

Unit:mm

Size	A(B)	ϕd	ϕD	$\phi D1$	$\phi D2$	ϕC	n- ϕh	Recommend Fasten Torqu N·m
□ 15(1/2)		18	86	25	38	60.5	4-16	14
□ 20(3/4)		23	97	33	48	70.1	4-16	14
□ 25(1)		30	107	38	53	79.5	4-16	20
□ 32(1-1/4)		38	114	51	66	88.9	4-16	20
□ 40(1-1/2)		43	124	53	69	98.6	4-16	20
□ 50(2)		53	150	69	84	120.7	4-19	34
□ 65(2-1/2)		69	175	86	102	139.7	4-19	34
□ 80(3)		81	188	99	112	152.4	4-19	41
□ 100(4)		102	226	119	137	190.5	8-19	41
□ 125(5)		127	251	145	165	215.9	8-22	55
□ 150(6)		149	277	168	191	241.3	8-22	68
□ 200(8)		198	340	216	246	298.5	8-22	68
□ 250(10)		249	404	269	307	362.0	12-25	89
□ 300(12)		300	480	325	353	431.8	12-25	102

Note: Flange bolt hole patterns meet ANSI B16.5 class 150.

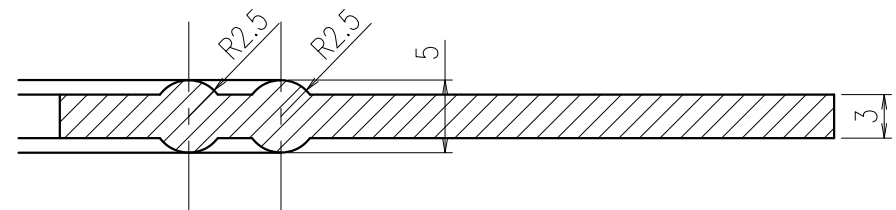

Client name		Date
Oil Free	<input type="checkbox"/> YES	Approved by:
ESLON EPDM GASKET ANSI B16.5 1/2"-12"		
Drawing No. PK153H_EP_AE		
SEKISUI SEKISUI CHEMICAL CO.,LTD.		

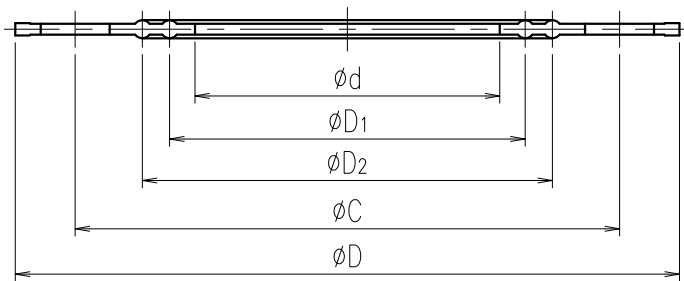
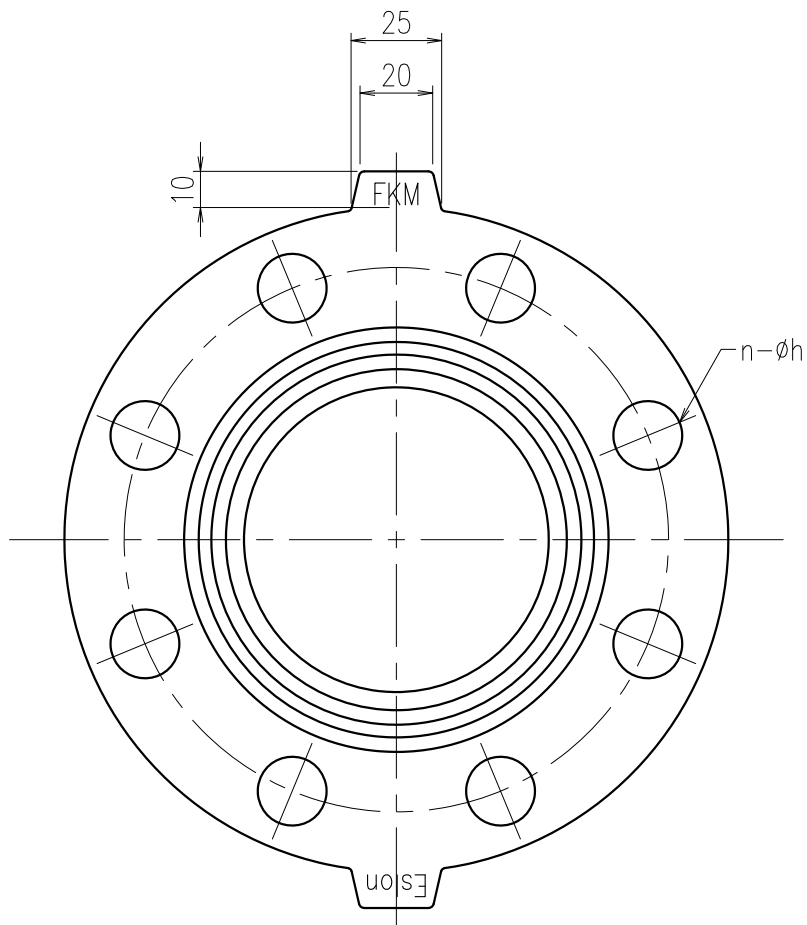

Dimension Table

Unit:mm

Size	A(B)	ϕd	ϕD	ϕD_1	ϕD_2	ϕC	n- ϕh	e	Recommend Fasten Torqu N·m
□ 15(1/2)	20	93	28	42	70	4-15	2.0	15	
□ 20(3/4)	25	98	33	47	75	4-15	2.0	15	
□ 25(1)	30	123	38	53	90	4-19	3.0	30	
□ 32(1-1/4)	38	133	48	63	100	4-19	3.0	30	
□ 40(1-1/2)	46	138	54	69	105	4-19	4.0	30	
□ 50(2)	58	153	68	83	120	4-19	4.0	30	
□ 65(2-1/2)	73	173	86	101	140	4-19	4.0	45	
□ 80(3)	84	183	98	113	150	8-19	4.0	45	
□ 100(4)	106	208	120	138	175	8-19	4.0	45	
□ 125(5)	131	248	145	168	210	8-23	5.0	55	
□ 150(6)	155	278	170	196	240	8-23	5.0	55	
□ 200(8)	204	328	218	248	290	12-23	5.0	55	
□ 250(10)	254	398	270	306	355	12-25	5.0	65	
□ 300(12)	304	443	324	356	400	16-25	5.0	65	

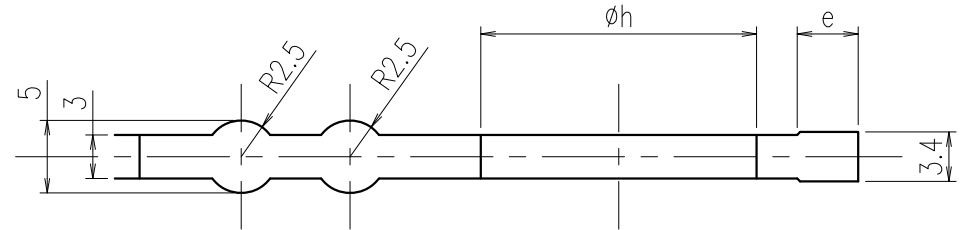

Client name		Date
Oil Free	<input type="checkbox"/> YES	Approved by:
ESLON FKM GASKET JIS10K 15-300A		
Drawing No. PK133H_FK_FE		
SEKISUI SEKISUI CHEMICAL CO.,LTD.		

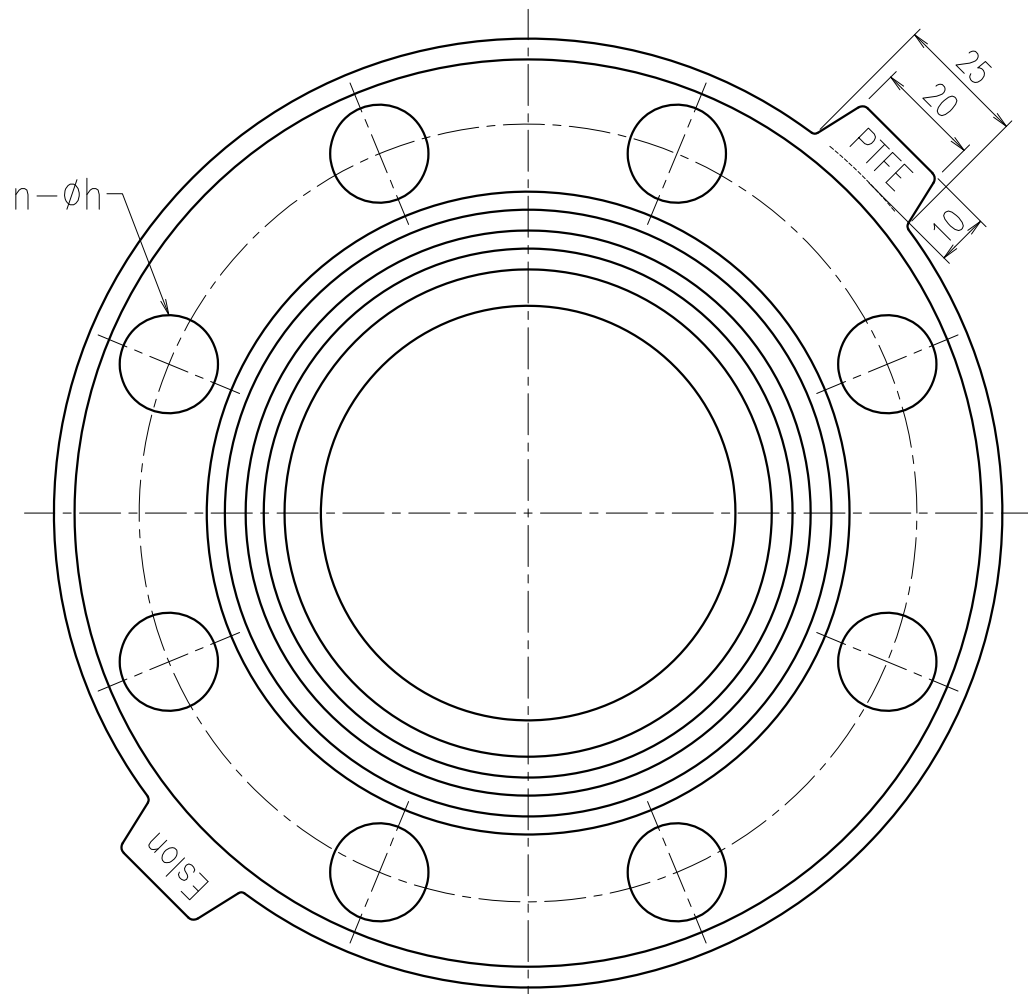

Dimension Table

Unit:mm

Designated Size	Nominal Diameter A(B)	Inside Diameter ød	Outside Diameter øD	Rib Position øD1	Rib Position øD2	Center Diameter øC	bolt Hole n-øh	e	torque Standards for Tightening N·m
<input type="checkbox"/>	13(3/8)	14	88	23	37	65	4-ø15	2.0	16
<input type="checkbox"/>	15(1/2)	18	93	26	41	70	4-ø15	2.0	16
<input type="checkbox"/>	20(3/4)	22	98	32	47	75	4-ø15	2.0	16
<input type="checkbox"/>	25(1)	30	123	38	53	90	4-ø19	3.0	34
<input type="checkbox"/>	30(1-1/4)	37	133	50	65	100	4-ø19	3.0	34
<input type="checkbox"/>	40(1-1/2)	43	138	54	69	105	4-ø19	4.0	34
<input type="checkbox"/>	50(2)	54	153	68	83	120	4-ø19	4.0	34
<input type="checkbox"/>	65(2-1/2)	69	173	86	101	140	4-ø19	4.0	51
<input type="checkbox"/>	80(3)	80	183	98	113	150	8-ø19	4.0	51
<input type="checkbox"/>	100(4)	102	208	120	138	175	8-ø19	4.0	51
<input type="checkbox"/>	125(5)	127	248	145	168	210	8-ø23	5.0	62
<input type="checkbox"/>	150(6)	150	278	168	190	240	8-ø23	5.0	62
<input type="checkbox"/>	200(8)	198	328	216	248	290	12-ø23	5.0	62
<input type="checkbox"/>	250(10)	249	398	270	306	355	12-ø25	5.0	73
<input type="checkbox"/>	300(12)	300	443	324	356	400	16-ø25	5.0	73

※ In the coating thickness of PTFE, 0.4mm is standards.

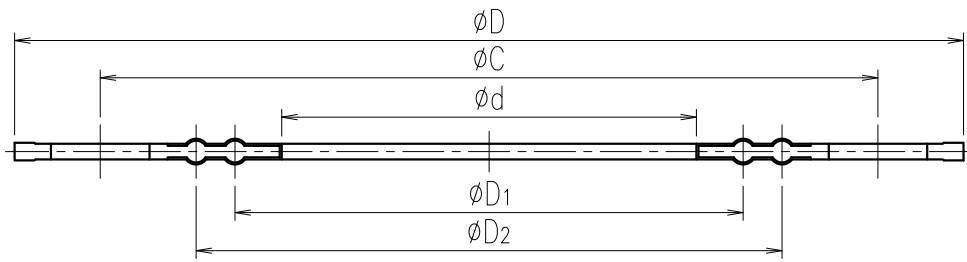
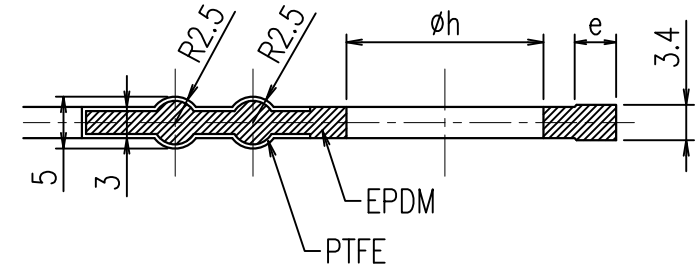

Please mark your requirements in the squares provided below.

Client name		Date	
Client Designations	<input type="checkbox"/> Non-Oil Process	<input type="checkbox"/> Necessary	Approved by:
	Other Special Items		
Item	ESLON PTFE GASKETS JIS 10K 13~300A		Drawing No. PK133H_PT_FE
SEKISUI CHEMICAL CO.,LTD.			

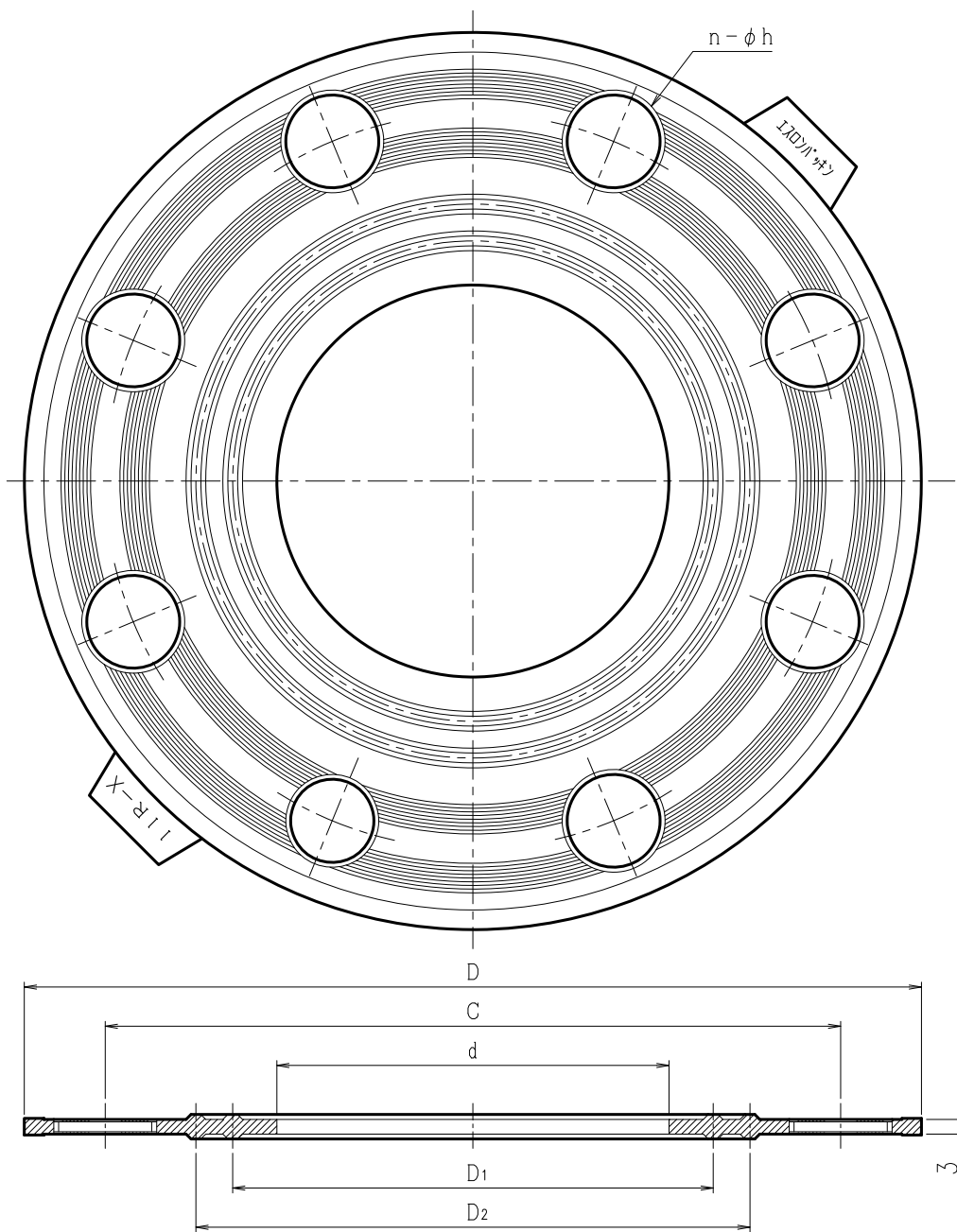

Dimension Table

Unit:mm

Size	A(B)	ϕd	ϕD	$\phi D1$	$\phi D2$	ϕC	$n-\phi h$	Recommend Fasten Torqu N·m
□ 13 (3/8)	14	88	23	37	65	4-15	15	
□ 15 (1/2)	18	93	26	41	70	4-15	15	
□ 20 (3/4)	22	98	32	47	75	4-15	15	
□ 25 (1)	28	123	38	53	90	4-19	30	
□ 32 (1.1/4)	37	133	50	65	100	4-19	30	
□ 40 (1.1/2)	43	138	54	69	105	4-19	30	
□ 50 (2)	54	153	68	83	120	4-19	30	
□ 65 (2.1/2)	69	173	86	101	140	4-19	45	
□ 80 (3)	80	183	98	113	150	8-19	45	
□ 100 (4)	102	208	120	138	175	8-19	45	
□ 125 (5)	127	248	145	168	210	8-23	55	
□ 150 (6)	150	278	168	190	240	8-23	55	
□ 200 (8)	198	328	216	248	290	12-23	55	
□ 250 (10)	250	398	270	306	355	12-23	65	

Client name		Date
Oil Free	<input type="checkbox"/> YES	Approved by:
ESLON IIR-X Gasket 13-250A		
Drawing No. PA132F_IR_FE		
SEKISUI SEKISUI CHEMICAL CO.,LTD.		

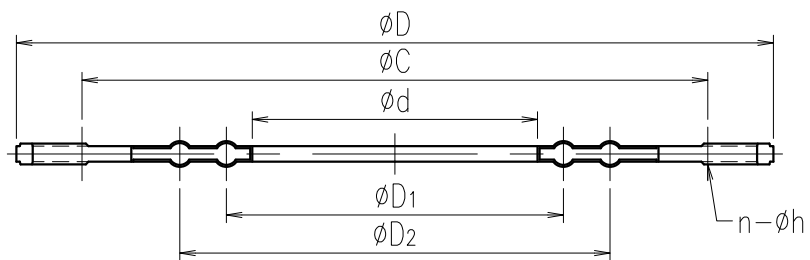
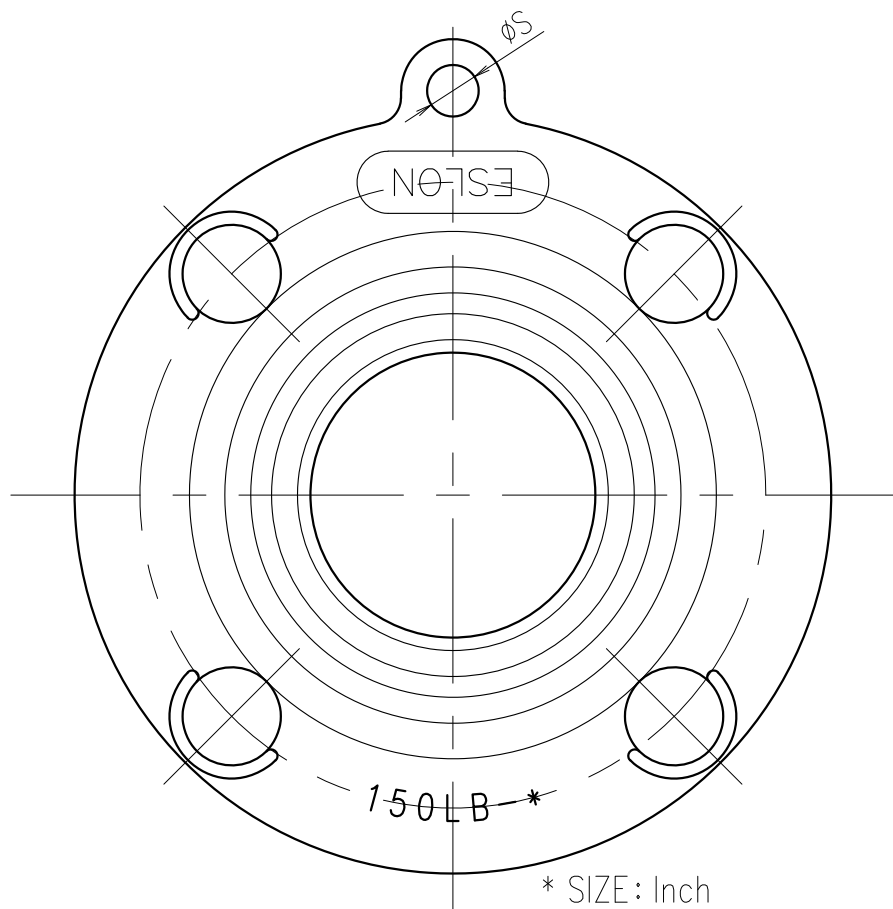

Dimension Table

Unit:mm

Size	A(B)	φd	φD	φD1	φD2	φC	n-φh	T	W	H	φS	Recommend Fasten Torqu N·m
□ 15 (1/2)	15	18	85	30	-	60.3	4-16	5	2.5	4	10	16
□ 20 (3/4)	20	22	95	32	44	69.9	4-16	5	2.5	4	10	16
□ 25 (1)	25	29	103	38	50	79.4	4-16	5	2.5	4	10	35
□ 32 (1-1/4)	32	39	111	47	59	88.9	4-16	5	2.5	4	10	35
□ 40 (1-1/2)	40	44	121	53	68	98.4	4-16	5	2.5	4	10	35
□ 50 (2)	50	55	146	65	83	120.7	4-19	5	2.5	4	10	35
□ 65 (2-1/2)	65	70	173	81	101	139.7	4-19	5	4	4	10	52
□ 80 (3)	80	81	186	94	112	152.4	4-19	5	4	4	10	52
□ 100 (4)	100	103	223	124	148	190.5	8-19	5	4	4	10	52
□ 125 (5)	125	128	249	150	174	215.9	8-22	5	4	4	12	68
□ 150 (6)	150	152	274	172	196	241.3	8-22	5	4	4	12	68
□ 200 (8)	200	200	337	222	146	298.5	8-22	5	4	4	12	63
□ 250 (10)	250	251	401	276	300	362.0	12-25	6	4	3.4	12	102
□ 300 (12)	300	302	477	335	365	431.8	12-25	6	4	3.4	12	136

Note: Flange bolt hole patterns meet ANSI B16.5 class 150.

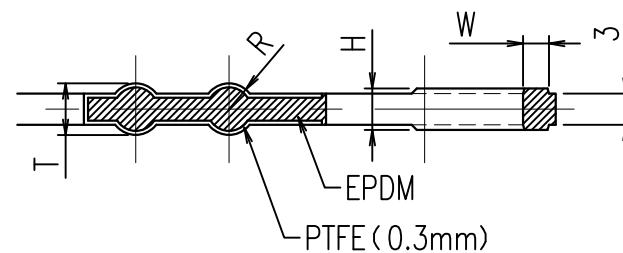

Client name		Date
Oil Free	<input type="checkbox"/> YES	Approved by:
ESLON PTFE GASKET ANSI B16.5 1/2"-12"		
Drawing No. PK133H_PT_AE		
SEKISUI SEKISUI CHEMICAL CO.,LTD.		