

No.	Part Name	Q'TY	Material/Type
1	Body	1	PVC
2	Ball	1	
3	Ring	1	
4	Screen	1	
5	Union Nut	1	
6	Seat	1	□EPDM □FKM

Dimension Table

Unit: mm

Size	A(B)	ϕd	ϕD_u	JIS				ASTM				DIN			
				ϕd_1	1/T	l	L	ϕd_1	ϕd_2	l	L	ϕd_1	ϕd_2	l	L
□ 15 (1/2)	16	49	22.3	1/37	22	119	21.54	21.23	22.2	116	20.3	20.1	16	104	
□ 20 (3/4)	20	59	26.3	1/42	25	140	26.87	26.57	25.4	132	25.3	25.1	19	121	
□ 25 (1)	25	67	32.3	1/43	29	151	33.65	33.27	28.6	146	32.3	32.1	22	133	
□ 32 (1-1/4)	32	98	38.4	1/37	32	205	42.42	42.04	31.8	205	40.3	40.1	26	201	
□ 40 (1-1/2)	40	98	48.5	1/38	35	205	48.56	48.11	35.0	203	50.3	50.1	31	194	
□ 50 (2)	50	120	60.6	1/34	38	235	60.63	60.17	38.1	227	63.3	63.1	38	228	
□ 65 (2 1/2)	65	150	76.6	1/48	61	309	73.38	72.85	44.5	272	75.3	75.1	44	272	
□ 80 (3)	78	150	89.6	1/49	64	335	89.31	88.70	47.6	296	90.3	90.1	51	297	
□ 100 (4)	102	228	114.7	1/56	84	480	114.76	114.10	57.2	424	110.4	110.4	61	428	

Remarks) Socket dimension is in accordance with the following standard;
ASTM D2467 for ASTM and DIN8063 for DIN

Client name		Date
Oil Free	<input type="checkbox"/> YES	Approved by:

ESLON Foot Valve
Socket Type SIZE 15 (1/2") - 100 (4")

Drawing No. | FV151HSE

SEKISUI SEKISUI CHEMICAL CO.,LTD.

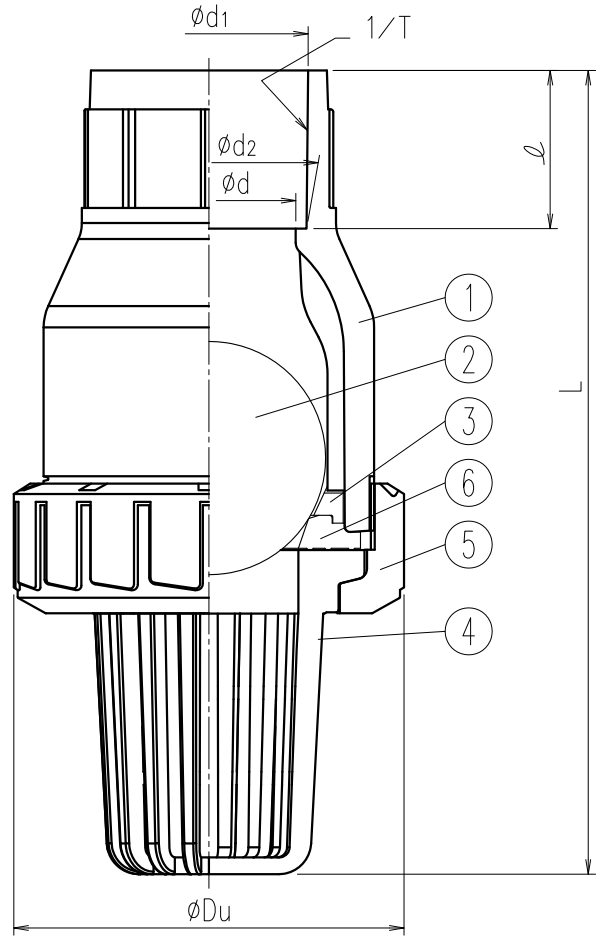

No.	Part Name	Q'TY	Material/Type
1	Body	1	HT (JIS)
2	Ball	1	C-PVC (ANSI)
3	Ring	1	
4	Screen	1	
5	Union Nut	1	
6	Seat	1	<input type="checkbox"/> EPDM <input type="checkbox"/> FKM

Dimension Table

Unit: mm

Size	A(B)	ϕd	ϕDu	JIS				ASTM				DIN			
				ϕd_1	1/T	l	L	ϕd_1	ϕd_2	l	L	ϕd_1	ϕd_2	l	L
<input type="checkbox"/> 15 (1/2)		16	49	22.3	1/37	22	119	21.54	21.23	22.2	116	20.3	20.1	16	104
<input type="checkbox"/> 20 (3/4)		20	59	26.3	1/42	25	140	26.87	26.57	25.4	132	25.3	25.1	19	121
<input type="checkbox"/> 25 (1)		25	67	32.3	1/43	29	151	33.65	33.27	28.6	146	32.3	32.1	22	133
<input type="checkbox"/> 32 (1-1/4)		32	98	38.4	1/37	32	205	42.42	42.04	31.8	205	40.3	40.1	26	201
<input type="checkbox"/> 40 (1-1/2)		40	98	48.5	1/38	35	205	48.56	48.11	35.0	203	50.3	50.1	31	194
<input type="checkbox"/> 50 (2)		50	120	60.6	1/34	38	235	60.63	60.17	38.1	227	63.3	63.1	38	228
<input type="checkbox"/> 65 (2 1/2)		65	150	76.6	1/48	61	309	73.38	72.85	44.5	272	75.3	75.1	44	272
<input type="checkbox"/> 80 (3)		78	150	89.6	1/49	64	335	89.28	88.67	47.6	296	90.3	90.1	51	297
<input type="checkbox"/> 100 (4)		102	228	114.7	1/56	84	480	114.76	114.10	57.2	424	110.4	110.4	61	428

Remarks) Socket dimension is in accordance with the following standard;
ASTM D2467 for ASTM and DIN8063 for DIN

Client name		Date
Socket Standard	<input type="checkbox"/> JIS <input type="checkbox"/> ASTM	Approved by:
Oil Free	<input type="checkbox"/> YES	

ESLON Foot Valve
Socket Type SIZE 15 (1/2") - 100 (4")
Drawing No. | FV151HSE-HT
SEKISUI SEKISUI CHEMICAL CO.,LTD.

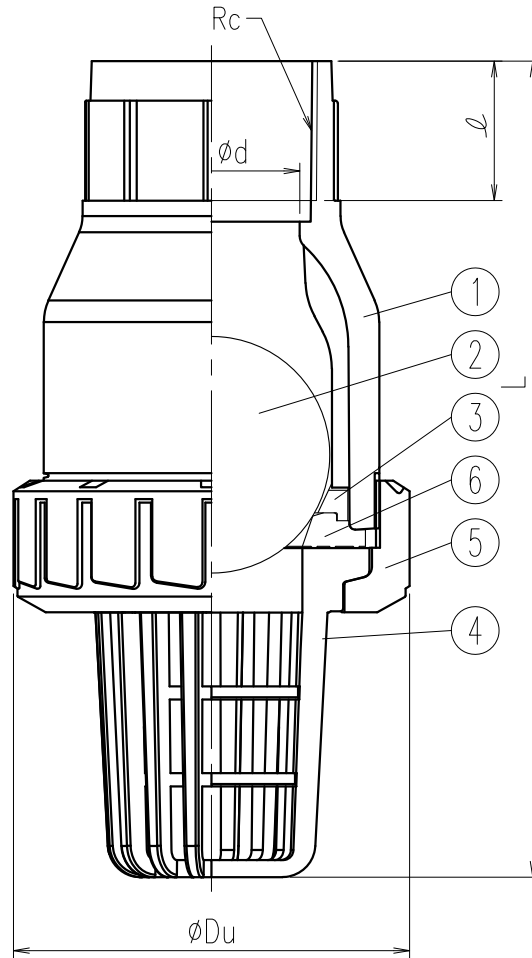

No.	Part Name	Q'TY	Material/Type
1	Body	1	PVC
2	Ball	1	
3	Ring	1	
4	Screen	1	
5	Union Nut	1	
6	Seat	1	<input type="checkbox"/> EPDM <input type="checkbox"/> FKM

Dimension Table

Unit: mm

Size	A (B)	ød	øDu	JIS:Rc		ANSI:NPT		DIN:Rp,Rc	
				ℓ	L	ℓ	L	ℓ	L
<input type="checkbox"/> 15 (1/2)	16	49	13	117	16.5	117	15.0	117	
<input type="checkbox"/> 20 (3/4)	20	59	15	137	17.0	137	16.5	137	
<input type="checkbox"/> 25 (1)	25	67	17	148	21.0	148	19.0	148	
<input type="checkbox"/> 32 (1-1/4)	32	98	19	208	22.0	208	22.0	208	
<input type="checkbox"/> 40 (1-1/2)	40	98	19	203	22.0	203	22.0	203	
<input type="checkbox"/> 50 (2)	50	120	23	237	23.0	237	26.0	237	
<input type="checkbox"/> 65 (2 1/2)	65	150	27	294	31.0	286	31.0	286	
<input type="checkbox"/> 80 (3)	78	150	37	320	37.0	319	37.0	320	
<input type="checkbox"/> 100 (4)	102	228	36	458	35.0	447	40.0	447	

Remarks) Thread dimension is in accordance with the following standard;
 JIS B 0203 for JIS, ANSI B1.20.1 and DIN2999 for DIN

Client name		Date
Thread Standard	<input type="checkbox"/> JIS (Rc) <input type="checkbox"/> ANSI (NPT) <input type="checkbox"/> DIN (Rp) <input type="checkbox"/> DIN (Rc)	Approved by:
Oil Free	<input type="checkbox"/> YES	
ESLON BALL FOOT VALVE FEMALE THREAD TYPE SIZE 15 (1/2") - 100 (4")		
Drawing No. FV151HNE		
SEKISUI SEKISUI CHEMICAL CO.,LTD.		

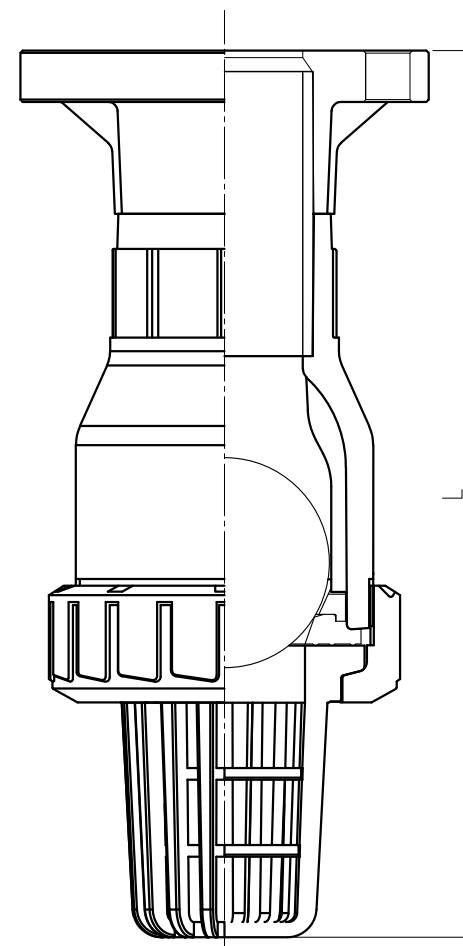
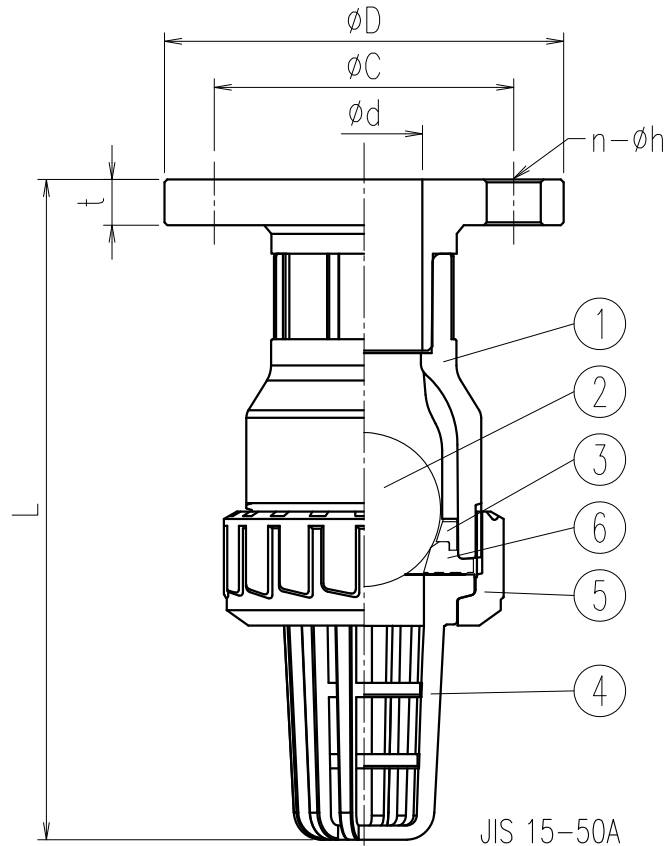

No.	Part Name	Q'TY	Material/Type
1	Body	1	PVC
2	Ball	1	
3	Ring	1	
4	Screen	1	
5	Union Nut	1	
6	Seat	1	<input type="checkbox"/> EPDM <input type="checkbox"/> FKM

Dimension Table

Unit: mm

Size	A(B)	ϕd	JIS10K Flange					ANSI Flange				
			L	ϕD	ϕC	$n-\phi h$	T	L	ϕD	ϕC	$n-\phi h$	T
<input type="checkbox"/> 15 (1/2)	16	139	95	70	4-15	14	145	89	60.3	4-16	11.5	
<input type="checkbox"/> 20 (3/4)	20	161	100	75	4-15	14	170	99	69.0	4-16	13.0	
<input type="checkbox"/> 25 (1)	25	175	125	90	4-19	14	183	108	79.5	4-16	14.5	
<input type="checkbox"/> 32 (1-1/4)	32	231	135	100	4-19	16	-	-	-	-	-	
<input type="checkbox"/> 40 (1-1/2)	40	232	140	105	4-19	16	246	128	98.4	4-16	19.0	
<input type="checkbox"/> 50 (2)	50	260	155	120	4-19	20	279	152	120.6	4-19	19.5	
<input type="checkbox"/> 65 (2 1/2)	65	379	175	140	4-19	22	344	177	139.5	4-19	22.5	
<input type="checkbox"/> 80 (3)	78	407	185	150	8-19	22	401	193	152.4	4-19	27.1	
<input type="checkbox"/> 100 (4)	102	570	210	175	8-19	24	524	230	190.5	8-19	29.3	

Note) Flange dimension is in accordance with the following standard;
JIS10K: JIS B 2220, ANSI: ASME/ANSI B16.5

JIS 65-100A
ANSI 15-100A

Client name		Date
Oil Free	<input type="checkbox"/> YES	Approved by:
ESLON BALL FOOT VALVE FLANGE TYPE SIZE 15 (1/2") - 100 (4")		
Drawing No. FV151HFE		
SEKISUI SEKISUI CHEMICAL CO.,LTD.		

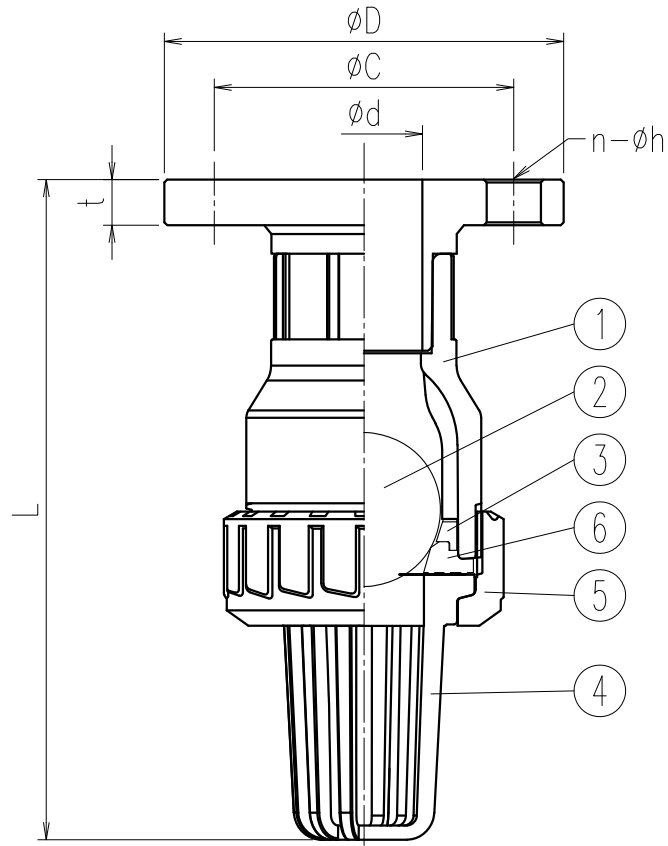

JIS 15-50A

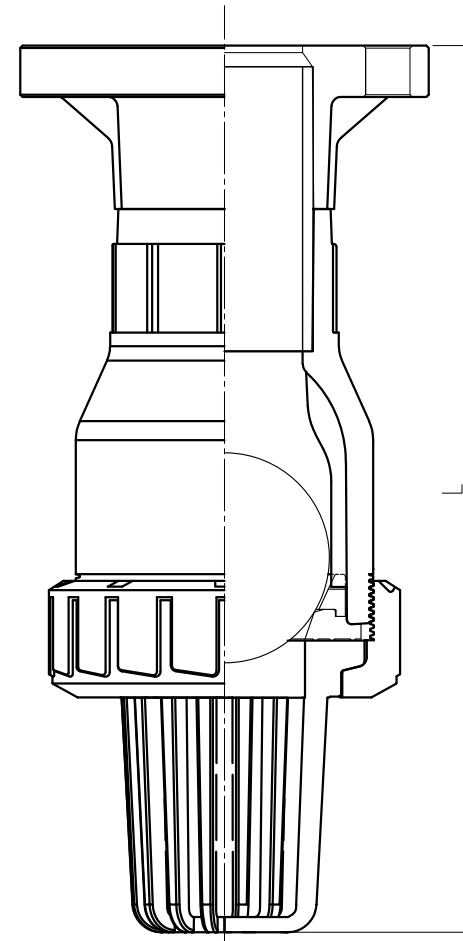

JIS 65-100A
ANSI 15-100A

No.	Part Name	Q'TY	Material/Type
1	Body	1	<input type="checkbox"/> HT (JIS)
2	Ball	1	<input type="checkbox"/> C-PVC (ANSI)
3	Ring	1	
4	Screen	1	
5	Union Nut	1	
6	Seat	1	<input type="checkbox"/> EPDM <input type="checkbox"/> FKM

Dimension Table

Unit: mm

Size	A(B)	ϕd	JIS10K Flange					ANSI Flange				
			L	ϕD	ϕC	$n-\phi h$	T	L	ϕD	ϕC	$n-\phi h$	T
<input type="checkbox"/> 15 (1/2)	16	139	95	70	4-15	14	145	89	60.3	4-16	11.5	
<input type="checkbox"/> 20 (3/4)	20	161	100	75	4-15	14	170	99	69.0	4-16	13.0	
<input type="checkbox"/> 25 (1)	25	175	125	90	4-19	14	183	108	79.5	4-16	14.5	
<input type="checkbox"/> 32 (1-1/4)	32	231	135	100	4-19	16	-	-	-	-	-	
<input type="checkbox"/> 40 (1-1/2)	40	232	140	105	4-19	16	246	128	98.4	4-16	19.0	
<input type="checkbox"/> 50 (2)	50	260	155	120	4-19	20	279	152	120.6	4-19	19.5	
<input type="checkbox"/> 65 (2 1/2)	65	379	175	140	4-19	22	344	177	139.5	4-19	22.5	
<input type="checkbox"/> 80 (3)	78	407	185	150	8-19	22	401	193	152.4	4-19	27.1	
<input type="checkbox"/> 100 (4)	102	570	210	175	8-19	24	524	230	190.5	8-19	29.3	

Note) Flange dimension is in accordance with the following standard;
JIS10K: JIS B 2220, ANSI: ASME/ANSI B16.5

Client name		Date
Socket Standard	<input type="checkbox"/> JIS <input type="checkbox"/> ANSI	Approved by:
Oil Free	<input type="checkbox"/> YES	

ESLON BALL FOOT VALVE
FLANGE TYPE SIZE 15 (1/2") - 100 (4")

Drawing No. | FV151HFE-HT

SEKISUI SEKISUI CHEMICAL CO.,LTD.