

(A) Indicator

No.	Part Name	QTY	Material/Type
1	Body	1	
2	Bonnet	1	
3	Indicator	1	PVC
4	Bush	1	
5	Disk Holder	1	
6	Pin	1	
7	O-Ring	1	□EPDM
8	O-Ring	1	□FKM
9	O-Ring	2	NBR
10	Collar	1	PP
11	Retaining Ring	1	15-20A C3604 25-32A PP
12	Stopper	1	SUS304
13	Indicator Stud Bolt	1	SUS304
14	Stem Sleeve	1	SUS304
15	Stem	1	SUS304
16	Disk	1	PP
17	Indicator Cover	1	PC
18	Indicator Stud Cover	1	C3604
19	Screw	4	SUS304
20	Screw	3	SUS304
21	O-Ring	1	NBR
22	O-Ring	1	NBR
23	Thrust Washer	1	SUS304
24	Screw	2	SUS304

Dimension Table

Unit: mm

SIZE	A(B)	ød	L	FLANGE				H	h	DH Ref.	Ref. Weight kg/unit
				øD	øC	n-øh	t				
□ 15(1/2)	16	85±1.5	95	70	4-15	14	217	170	80	0.8	
□ 20(3/4)	21	95±1.5	100	75	4-15	14	232	182	80	1.0	
□ 25(1)	26	110±1.5	125	90	4-19	14	255	192	80	1.4	
□ 32(1 1/4)	32	135±1.5	135	100	4-19	16	275	207	80	1.7	

Note) Flange dimension is in accordance with the following standard;JIS B 2220

Client name		Date
Rinsed	<input type="checkbox"/> YES	Approved by:
ESLON NEEDLE VALVE INDICATOR HANDLE TYPE 15-32A Drawing No.   NH1532FE		
<b>SEKISUI SEKISUI CHEMICAL CO.,LTD.</b>		

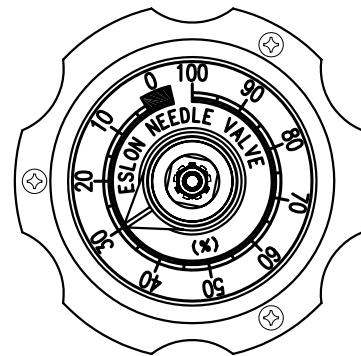
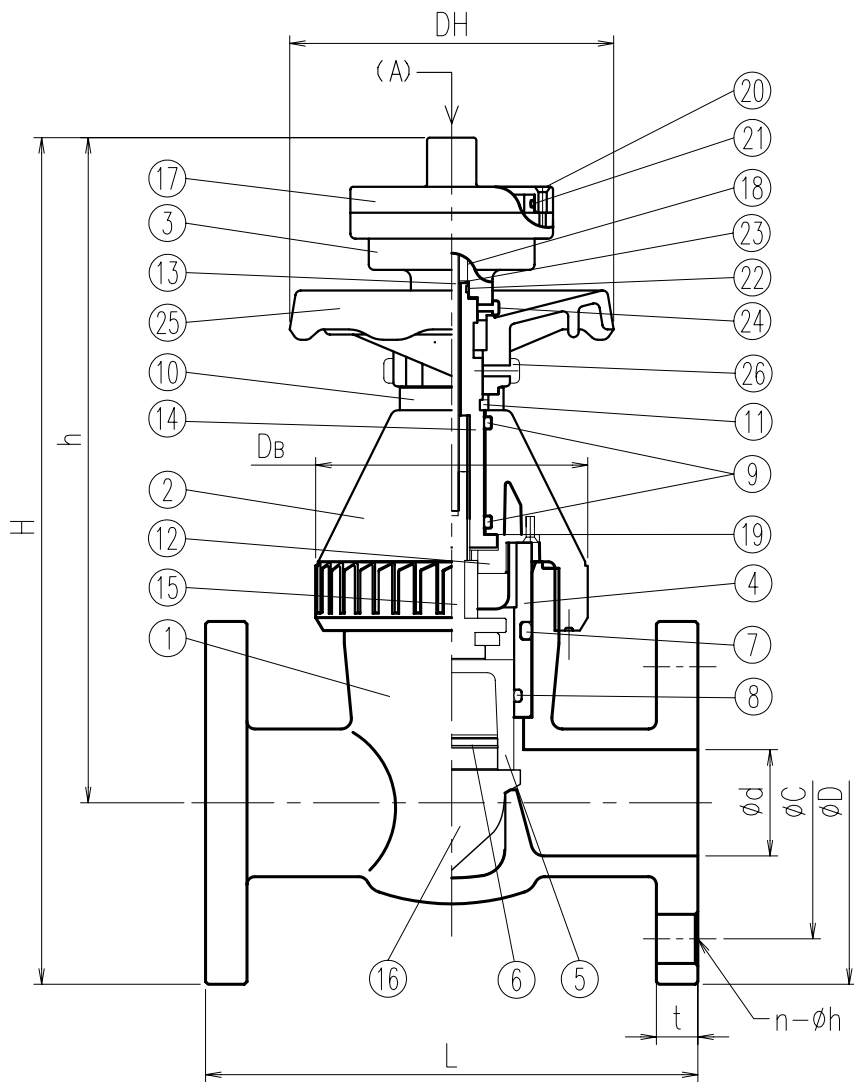

(A) Indicator

No.	Part Name	Q'TY	Material/Type
1	Body	1	
2	Bonnet	1	
3	Indicator	1	PVC
4	Bush	1	
5	Disk Holder	1	
6	Pin	1	
7	O-Ring	1	□EPDM
8	O-Ring	1	□FKM
9	O-Ring	2	NBR
10	Collar	1	PP
11	Retaining Ring	1	PP
12	Stopper	1	SUS304
13	Indicator Stud Bolt	1	SUS304
14	Stem Sleeve	1	SUS304
15	Stem	1	SUS304
16	Disk	1	PP
17	Indicator Cover	1	PC
18	Indicator Stud Cover	1	C3604
19	Screw	4	SUS304
20	Screw	3	SUS304
21	O-Ring	1	NBR
22	O-Ring	1	NBR
23	Thrust Washer	1	SUS304
24	Screw	2	SUS304
25	Handle	1	ABS
26	Screw	2	SUS304

Dimension Table

Unit: mm

SIZE	A(B)	ød	L	FLANGE				H	h	Handle DH	DB	Ref. Weight kg/unit
				øD	øC	n-øh	t					
□	40(1.1/2)	41	190±1.5	140	105	4-19	16	328	257	125	105	2.5

Note) Flange dimension is in accordance with the following standard;JIS B 2220

Client name		Date
Rinsed	<input type="checkbox"/> YES	Approved by:
ESLON NEEDLE VALVE INDICATOR HANDLE TYPE 40A Drawing No.  NI140FE		
<b>SEKISUI SEKISUI CHEMICAL CO.,LTD.</b>		